CKAS U2s 3DOF Motion System (220kg / 500lb Payload)



Introduction

The CKAS U2s 3DOF Motion System, is specifically directed at **very low cost mid fidelity small scale motion simulator applications**, such as commercial and industrial simulators, consumer coin-operated arcade entertainment simulators or home built flight and racing entertainment simulators.

Target Applications

- **Small Scale Low Cost Mid Fidelity Flight Training Applications**
- **Small Scale Commercial Vehicle and Truck Driver Training Simulators**
- **Small Scale Mining Equipment Simulators and Heavy Earth Moving Equipment Simulators**
- **Small Scale Train Driver Simulators**
- **Next Generation Unsupervised Coin-operated Motion Simulator Arcade Machines**
- **Home Built Mid Fidelity Flight Simulators**
- **Home Built Mid Fidelity Car Racing Simulators.**

General Description and Capabilities

The CKAS U2s 3DOF Motion System is Ideal for OEM manufacturers of existing simulator products or home builders who are looking for a cost effective method to instantly add motion to an existing or new design. This unit is pre-built to CKAS standards, and is USB plug and play straight out of the box. The only assembly required is to bolt on whatever goes on top of the motion system.

The CKAS U2s 3DOF Motion System features a mere 120kg total weight, 800mm total width for easily passing through doorways, and sits only 325mm high, therefore eliminating the need for any specialised stair or gangway for stepping up onto it. CKAS has used the technology it has developed for the heavier motion systems to design this unit, incorporating industry leading electronics, encoders and actuators.

The expected life of the U2s is extremely high for its price point, and the maintenance requirements are minimal, especially important in commercial or consumer based applications.

The CKAS U2s 3DOF motion system comes with the following key features:

- Fully Electric Actuation
- USB 2.0 plug and play
- Ethernet 100BaseT interface for custom OS/Platform independent applications (optional extra)
- On board Washout filters and acceleration onset cueing algorithms for many supported titles constantly growing (see website for all current supported games and simulator programs)
- Generic custom user program or other systems with full washout cueing, inverse kinematics, forward kinematics and full diagnostics on board the motion system
- Configurable to be connected directly to X-Sim to support over 50 other popular games such as Dirt/Dirt2/Dirt3 F1 2010/2011/2012/2013/2014 and many more
- Basic Serial over USB or optionally UDP (over Ethernet or Local) interface for immediate connection to custom software
- Very high speed update 100Hz motion controller for extremely smooth high fidelity response

Specific “On-board” Functionalities

This motion system features the CKAS Generation III controller which has some very high level functionality available to the user, without the need for any CKAS software to be running on a host PC. The client software can directly interface to the motion system at a very high level, and is even platform independent with the optional Ethernet Module installed.

The CKAS Generation III controller features the following specific capabilities on board:

- **Full Inverse Kinematics** allowing the user to drive the machine in Cartesian co-ordinates from any custom application, over either USB serial (Windows/Linux only) or completely platform independent through an optional Ethernet Interface.
- **Full Forward Kinematics** allowing the user to read the actual current position of the motion system in real-time, allowing for a wide range of applications, including when the visual system is not mounted on the motion system and needs to be synchronised in the graphics (client software required to perform the graphical synchronisation).
- **Washout Cueing Filters** allowing the client to send high level kinematics data to the motion system in order to recreate the vehicle motion through the washout filters, all completely independent of any other software, and even completely platform independent on the optional Ethernet Interface.

General Specifications

(Subject to change without notification)

Product Name	CKAS U2s 3DOF Motion System
Product Code	U2sMP
Product Number	32.0001.11
Product Description	Small Scale 3 degree of freedom heave-pitch-roll electric motion system
Harmonization Code (HS)	854370 or 854380 or 8543.70.96.50 (depending on Harmonisation system)

Mechanical Specifications

Architecture	3 Degree of Freedom Floating Centre Heave – Pitch – Roll
Actuation	Fully Electric
Nominal Width (Parked)	800 mm (31.5")
Nominal Length (Parked)	1180 mm (46.5")
Nominal Height (Parked)	325 mm (12.8")
Approx unit weight	120 kg (265 lb)
Anchoring Specification	Not required for this motion system

Performance Specifications

Payload Mass Limit	220 kg (500lb)
Payload Moment of Inertia	100 kg.m ² (2.370 lb.ft ²)
Payload CG horizontal offset	Less than 50mm from Centroid of Flying Platform
Payload CG Vertical offset	Less than 600mm high from top of Flying Platform
Payload Max Floor Size	2000mm x 2000mm (79" x 79")
Indep. Surge (disp. / vel. / accel.)	Not actuated
Indep. Sway (disp. / vel. / accel.)	Not actuated
Indep. Heave (disp. / vel. / accel.)	±38mm , ±150mm/s , 0.3G
Indep. Yaw (disp. / vel. / accel.)	Not actuated
Indep. Pitch (disp. / vel. / accel.)	±9° , ±15°/s , ±150°/s ²
Indep. Roll (disp. / vel. / accel.)	±10° , ±15°/s , ±150°/s ²
Max Motion Excitation Frequency	50 Hz

Electrical Specifications

Power Supply Requirements	200 – 250V AC Single Phase @ 8 Amps
PC Connectivity	USB 2.0
Controller Update Frequency	100 Hz

Software Specifications

Interface Protocols	Serial over USB (Windows/Linux) / Optional Ethernet (OS independent)
Washout Algorithm Drive	Washout System with 6DOF optimisations for: <ul style="list-style-type: none">• Many supported games and simulator programs (see website for complete details)• Generic User Applications (any platform with Ethernet)
Direct Drive	Extended command set over Serial or (optional) Ethernet

CKAS U2s 3DOF Motion System Engineering Dimensions

(Subject to change without notification)

View of Flying Platform from TOP

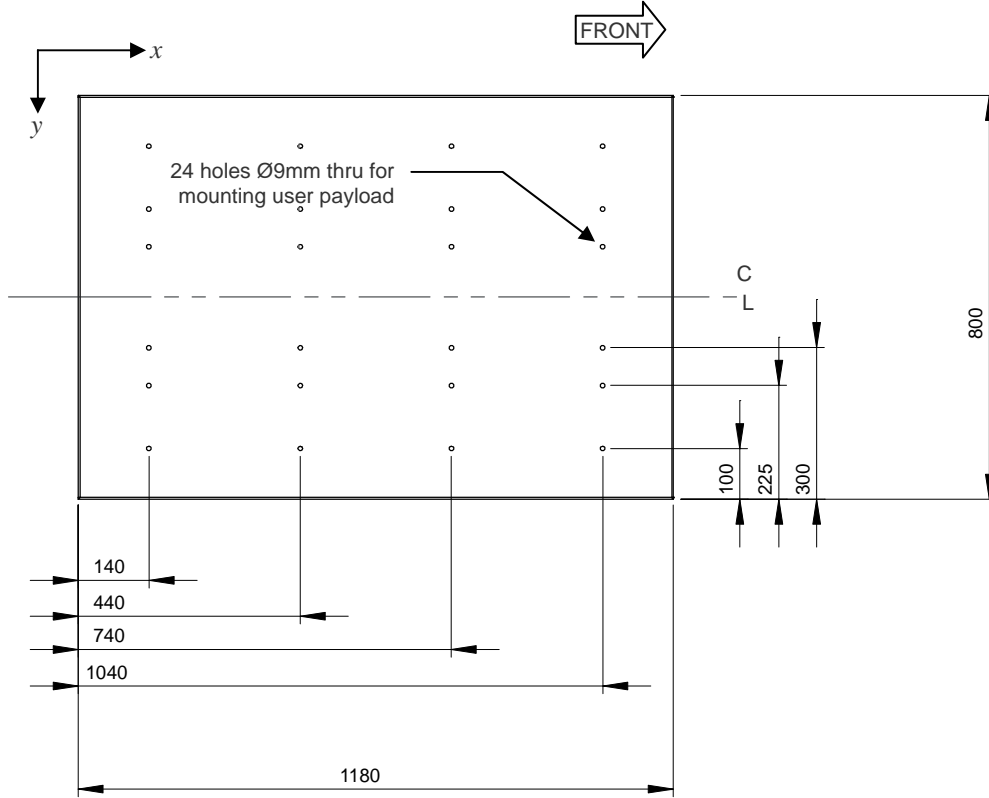

View of Motion System from RIGHT

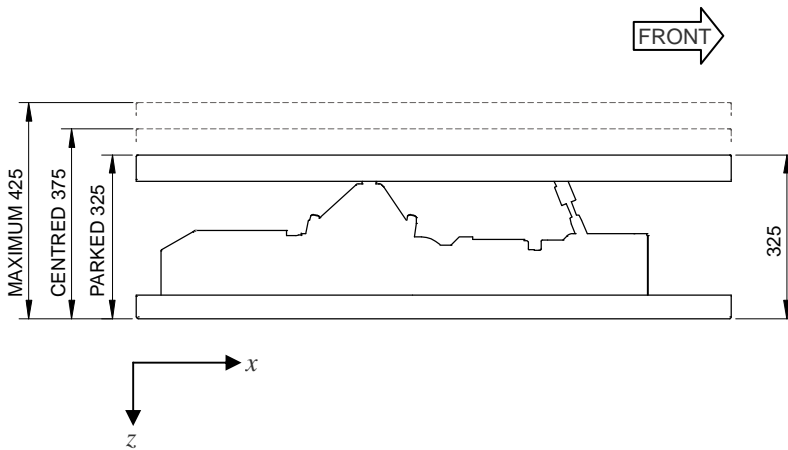

View of Motion System from FRONT

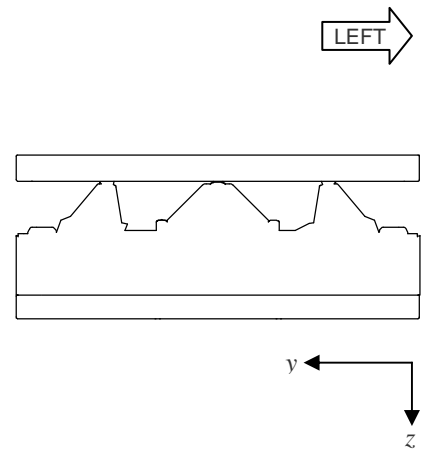

CKAS U5 3DOF Motion System (500kg / 1100lb Payload)



Introduction

The CKAS U5 3DOF Motion System is specifically directed at **mid weight professional motion simulator applications and serious home enthusiasts**, such as commercial and industrial simulators, operator manned arcade entertainment simulators or custom built flight simulators which require a **medium level of fidelity**.

Target Applications

- **Medium Scale Medium Fidelity Flight Training Simulators for up to 2 people**
- **Medium Scale Military Training Simulators for up to 2 people**
- **Medium Scale Medium Fidelity Commercial Vehicle and Truck Driver Training Simulators**
- **Medium Scale Mining Equipment Simulators and Heavy Earth Moving Equipment Simulators**
- **Medium Scale Medium Fidelity Train Driver Simulators for up to 2 people**
- **Medium Scale Medium Fidelity Research Platforms**

General Description and Capabilities

The CKAS U5 3DOF Motion System is Ideal for OEM manufacturers of existing simulator products or home builders who are looking for a cost effective method to add medium fidelity motion to an existing or new design. This unit is built to CKAS standards, and is USB plug and play straight out of the box. The only assembly required is to bolt on whatever goes on top of the motion system.

The CKAS U5 3DOF Motion System is serious motion unit, and features a lightweight plate structure, can carry 500kg, can swing through 18° in any axis, make an excursion of 140mm in the heave direction, and a high enough architecture to take a 2.5m size payload. The technology used on this professional 3DOF system is “best in class”, incorporating industry leading electronics, encoders and actuators.

The expected life of the U5 is extremely high, and the maintenance requirements are minimal, especially important in commercial or military based applications.

The CKAS U5 3DOF motion system comes with the following key features:

- Fully Electric Actuation
- USB 2.0 plug and play
- Ethernet 100BaseT interface for custom OS/Platform independent applications (optional extra)
- On board Washout filters and acceleration onset cueing algorithms for many supported titles constantly growing (see website for all current supported games and simulator programs)
- Generic custom user program or other systems with full washout cueing, inverse kinematics, forward kinematics and full diagnostics on board the motion system
- Configurable to be connected directly to X-Sim to support over 50 other popular games such as Dirt/Dirt2/Dirt3 F1 2010/2011/2012/2013/2014 and many more
- Basic Serial over USB or optionally UDP (over Ethernet or Local) interface for immediate connection to custom software
- Very high speed update 100Hz motion controller for extremely smooth high fidelity response

Specific “On-board” Functionalities

This motion system features the CKAS Generation III controller which has some very high level functionality available to the user, without the need for any CKAS software to be running on a host PC. The client software can directly interface to the motion system at a very high level, and is even platform independent with the optional Ethernet Module installed.

The CKAS Generation III controller features the following specific capabilities on board:

- **Full Inverse Kinematics** allowing the user to drive the machine in Cartesian co-ordinates from any custom application, over either USB serial (Windows/Linux only) or completely platform independent through an optional Ethernet Interface.
- **Full Forward Kinematics** allowing the user to read the actual current position of the motion system in real-time, allowing for a wide range of applications, including when the visual system is not mounted on the motion system and needs to be synchronised in the graphics (client software required to perform the graphical synchronisation).
- **Washout Cueing Filters** allowing the client to send high level kinematics data to the motion system in order to recreate the vehicle motion through the washout filters, all completely independent of any other software, and even completely platform independent on the optional Ethernet Interface.

General Specifications

(Subject to change without notification)

Product Name	CKAS U5 3DOF Motion System
Product Code	U5MP
Product Number	30.0001.11
Product Description	Medium Scale 6 degree of freedom electric motion system
Harmonization Code (HS)	854370 or 854380 or 8543.70.96.50 (depending on Harmonisation system)

Mechanical Specifications

Architecture	3 Degree of Freedom Floating Centre Heave-Pitch-Roll (HPR)
Actuation	Fully Electric
Nominal Width (Parked)	1785 mm (70.3")
Nominal Length (Parked)	1550 mm (61.0")
Nominal Height (Parked)	650 mm (25.6")
Approx unit weight	450 kg (990 lb)
Anchoring Specification	3 places 16mm holes distributed to be anchored with 12-14mm fasteners

Performance Specifications

Payload Mass Limit	500 kg (1100lb)
Payload Moment of Inertia	250 kg.m ² (5,930 lb.ft ²)
Payload CG horizontal offset	Less than 100mm from Centroid of Flying Platform
Payload CG Vertical offset	Less than 600mm high from top of Flying Platform
Payload Max Floor Size	Diameter 2500mm (98")
Indep. Heave (disp. / vel. / accel.)	±140mm , ±280mm/s , 0.5G
Indep. Pitch (disp. / vel. / accel.)	±18° , ±35°/s , ±400°/s ²
Indep. Roll (disp. / vel. / accel.)	±18° , ±35°/s , ±400°/s ²
Max Motion Excitation Frequency	50 Hz

Electrical Specifications

Power Supply Requirements	200 – 250V AC Single Phase @ 16 Amps hard wired (no RCD)
Safety Interlocks	External User Park and Current Position Freeze on Power Fail
PC Connectivity	USB 2.0
Controller Update Frequency	100 Hz

Software Specifications

Interface Protocols	Serial over USB (Windows/Linux) / Optional Ethernet (OS independent)
Washout Algorithm Drive	Washout System with 6DOF optimisations for: <ul style="list-style-type: none">• Many supported games and simulator programs (see website for complete details)• Generic User Applications (any platform with Ethernet)
Direct Drive	Extended command set over Serial or (optional) Ethernet

View of Base Mounting Holes from TOP

View of Flying Platform from TOP

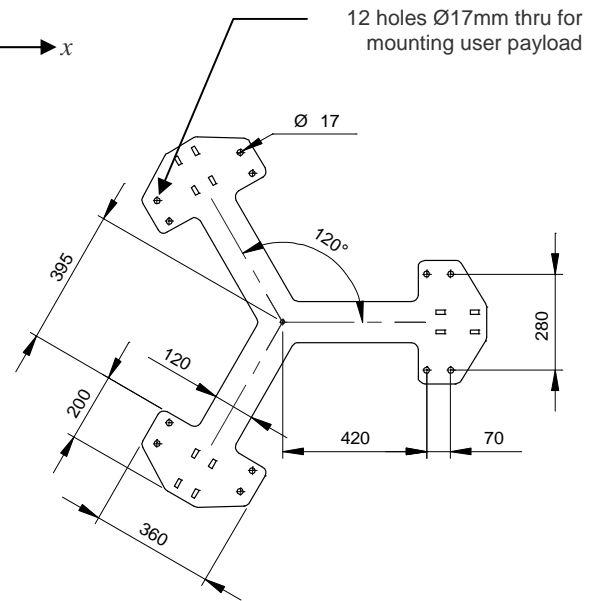
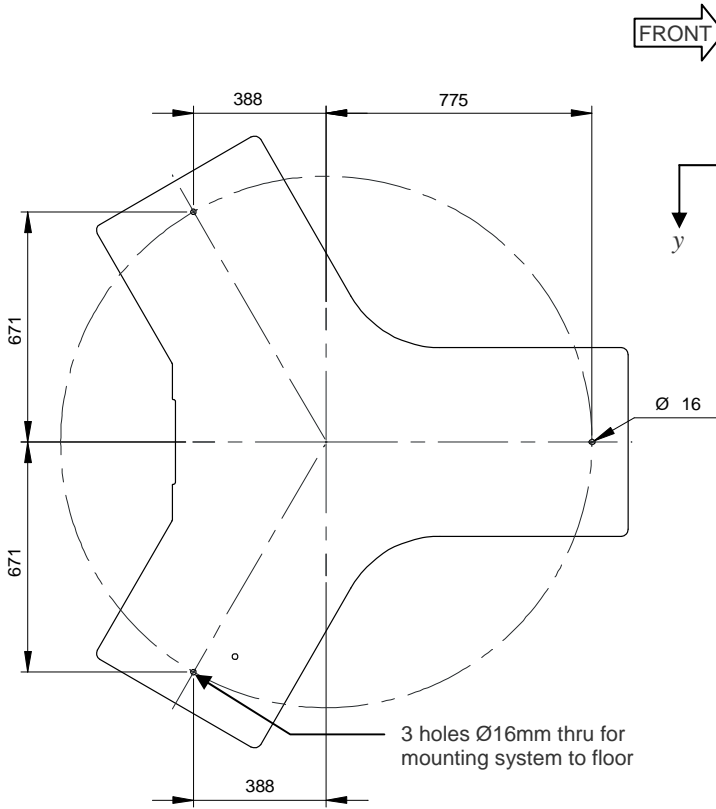

View of Motion System from RIGHT

View of Motion System from FRONT

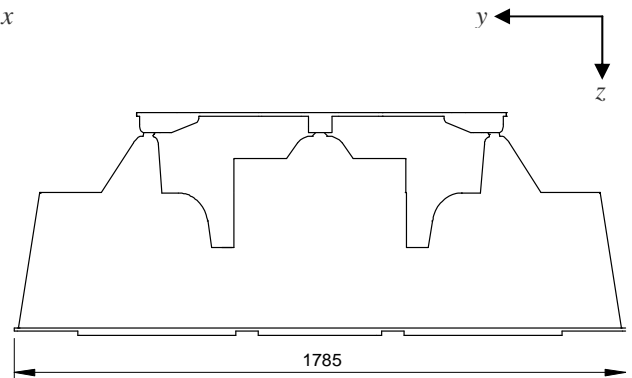
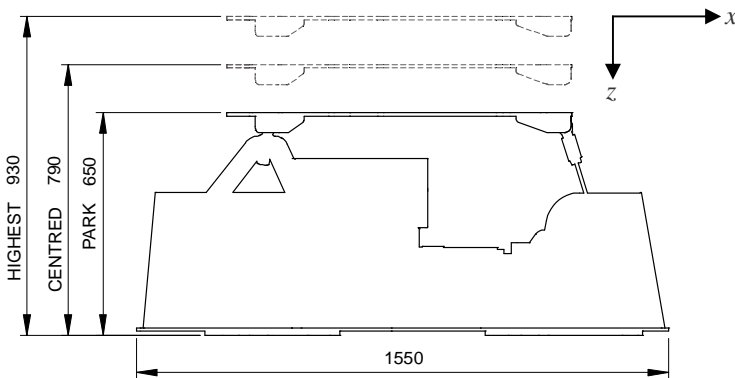

CKAS U10 3DOF Motion System (1000kg / 2200lb Payload)



Introduction

The CKAS U10 3DOF Motion System is specifically directed at **mid weight professional motion simulator applications and serious home enthusiasts**, such as commercial and industrial simulators, operator manned arcade entertainment simulators or custom built flight simulators which require a **medium level of fidelity**.

Target Applications

- **Medium Scale Medium Fidelity Flight Training Simulators for up to 2 people**
- **Medium Scale Military Training Simulators for up to 2 people**
- **Medium Scale Medium Fidelity Commercial Vehicle and Truck Driver Training Simulators**
- **Medium Scale Mining Equipment Simulators and Heavy Earth Moving Equipment Simulators**
- **Medium Scale Medium Fidelity Train Driver Simulators for up to 2 people**
- **Medium Scale Medium Fidelity Research Platforms**

General Description and Capabilities

The CKAS U10 3DOF Motion System is Ideal for OEM manufacturers of existing simulator products or home builders who are looking for a cost effective method to add medium fidelity motion to an existing or new design. This unit is built to CKAS standards, and is USB plug and play straight out of the box. The only assembly required is to bolt on whatever goes on top of the motion system.

The CKAS U10 3DOF Motion System is serious motion unit, and features a lightweight plate structure, can carry 1000kg, can swing through 18° in any axis, make an excursion of 140mm in the heave direction, and a high enough architecture to take a 2.5m size payload. The technology used on this professional 3DOF system is “best in class”, incorporating industry leading electronics, encoders and actuators.

The expected life of the U10 is extremely high, and the maintenance requirements are minimal, especially important in commercial or military based applications.

The CKAS U10 3DOF motion system comes with the following key features:

- Fully Electric Actuation
- USB 2.0 plug and play
- Ethernet 100BaseT interface for custom OS/Platform independent applications (optional extra)
- On board Washout filters and acceleration onset cueing algorithms for many supported titles constantly growing (see website for all current supported games and simulator programs)
- Generic custom user program or other systems with full washout cueing, inverse kinematics, forward kinematics and full diagnostics on board the motion system
- Configurable to be connected directly to X-Sim to support over 50 other popular games such as Dirt/Dirt2/Dirt3 F1 2010/2011/2012/2013/2014 and many more
- Basic Serial over USB or optionally UDP (over Ethernet or Local) interface for immediate connection to custom software
- Very high speed update 100Hz motion controller for extremely smooth high fidelity response

Specific “On-board” Functionalities

This motion system features the CKAS Generation III controller which has some very high level functionality available to the user, without the need for any CKAS software to be running on a host PC. The client software can directly interface to the motion system at a very high level, and is even platform independent with the optional Ethernet Module installed.

The CKAS Generation III controller features the following specific capabilities on board:

- **Full Inverse Kinematics** allowing the user to drive the machine in Cartesian co-ordinates from any custom application, over either USB serial (Windows/Linux only) or completely platform independent through an optional Ethernet Interface.
- **Full Forward Kinematics** allowing the user to read the actual current position of the motion system in real-time, allowing for a wide range of applications, including when the visual system is not mounted on the motion system and needs to be synchronised in the graphics (client software required to perform the graphical synchronisation).
- **Washout Cueing Filters** allowing the client to send high level kinematics data to the motion system in order to recreate the vehicle motion through the washout filters, all completely independent of any other software, and even completely platform independent on the optional Ethernet Interface.

General Specifications

(Subject to change without notification)

Product Name	CKAS U10 3DOF Motion System
Product Code	U10MP
Product Number	31.0001.11
Product Description	Medium Scale 6 degree of freedom electric motion system
Harmonization Code (HS)	854370 or 854380 or 8543.70.96.50 (depending on Harmonisation system)

Mechanical Specifications

Architecture	3 Degree of Freedom Floating Centre Heave-Pitch-Roll (HPR)
Actuation	Fully Electric
Nominal Width (Parked)	1785 mm (70.3")
Nominal Length (Parked)	1550 mm (61.0")
Nominal Height (Parked)	650 mm (25.6")
Approx unit weight	480 kg (1060 lb)
Anchoring Specification	3 places 16mm holes distributed to be anchored with 12-14mm fasteners

Performance Specifications

Payload Mass Limit	1000 kg (2200lb)
Payload Moment of Inertia	450 kg.m ² (10,700 lb.ft ²)
Payload CG horizontal offset	Less than 100mm from Centroid of Flying Platform
Payload CG Vertical offset	Less than 600mm high from top of Flying Platform
Payload Max Floor Size	Diameter 2500mm (98")
Indep. Heave (disp. / vel. / accel.)	±140mm , ±280mm/s , 0.5G
Indep. Pitch (disp. / vel. / accel.)	±18° , ±35°/s , ±400°/s ²
Indep. Roll (disp. / vel. / accel.)	±18° , ±35°/s , ±400°/s ²
Max Motion Excitation Frequency	50 Hz

Electrical Specifications

Power Supply Requirements	200 – 250V AC Single Phase @ 25 Amps hard wired (no RCD)
Safety Interlocks	External User Park and Current Position Freeze on Power Fail
PC Connectivity	USB 2.0
Controller Update Frequency	100 Hz

Software Specifications

Interface Protocols	Serial over USB (Windows/Linux) / Optional Ethernet (OS independent)
Washout Algorithm Drive	Washout System with 6DOF optimisations for: <ul style="list-style-type: none">• Many supported games and simulator programs (see website for complete details)• Generic User Applications (any platform with Ethernet)
Direct Drive	Extended command set over Serial or (optional) Ethernet

View of Base Mounting Holes from TOP

View of Flying Platform from TOP

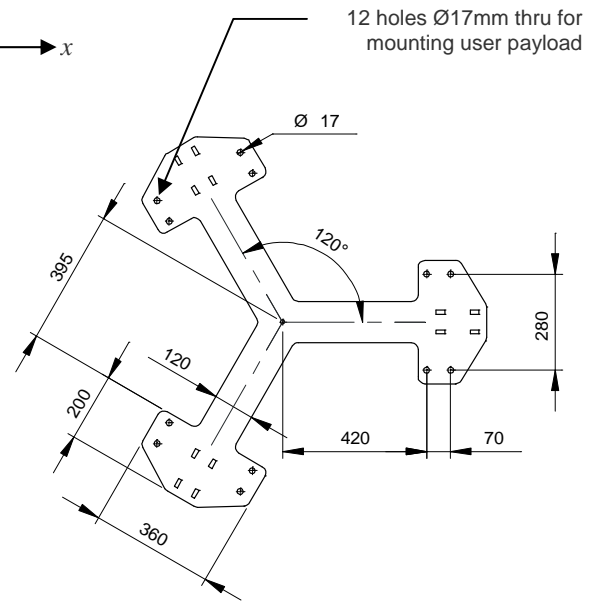
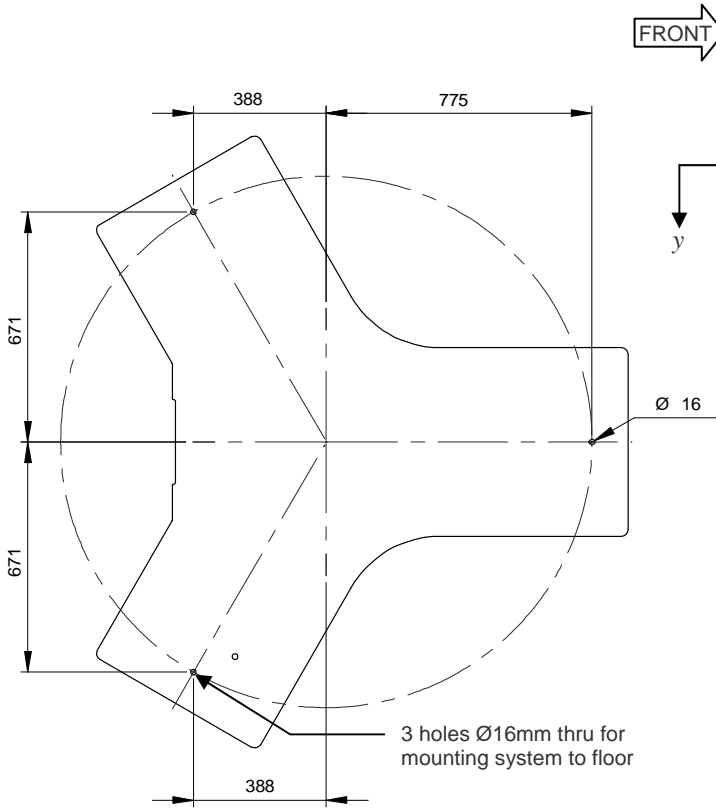

View of Motion System from RIGHT

View of Motion System from FRONT

