

---

## CKAS W3s 6DOF Motion System (300kg / 660lb Payload)

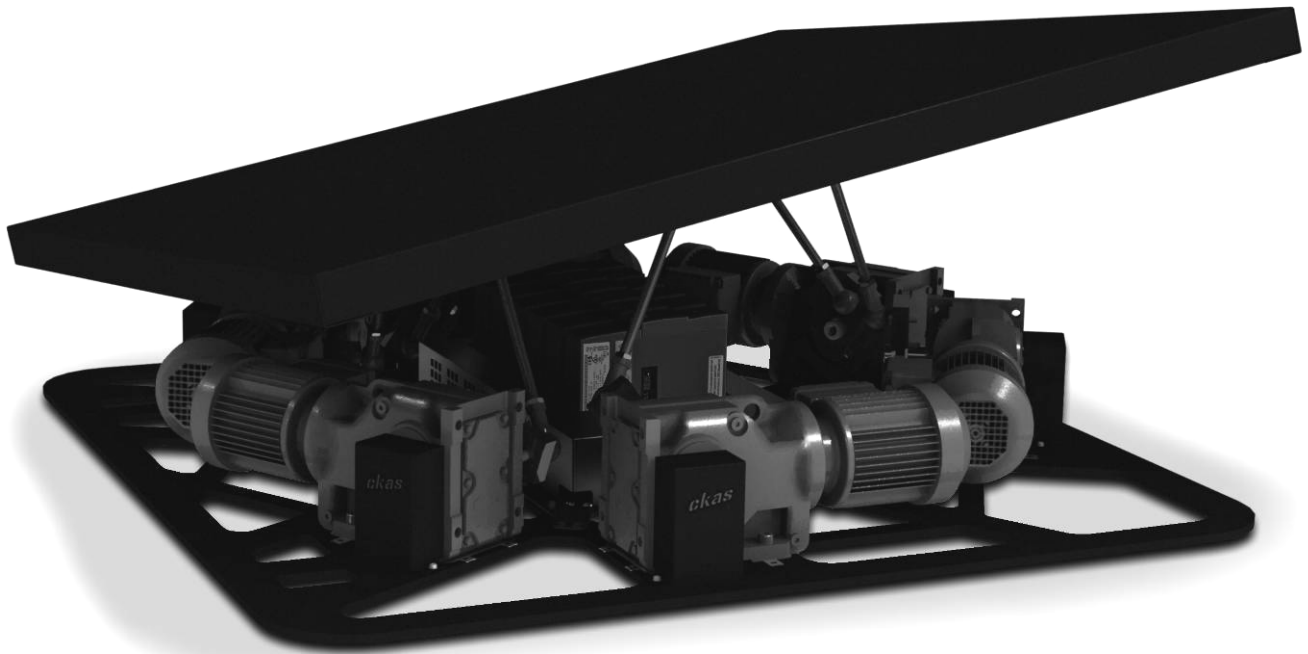

---

### Introduction

The CKAS W3s 6DOF Motion System is specifically directed at **low cost high fidelity small scale motion simulator applications**, such as commercial and industrial simulators, next generation consumer coin-operated arcade entertainment simulators or hi fidelity home built flight and racing entertainment simulators.

### Target Applications

- **Small Scale Low Cost Hi fidelity Flight Training Applications**
- **Small Scale Hi fidelity Commercial Vehicle and Truck Driver Training Simulators**
- **Small Scale Hi fidelity Mining Equipment Simulators and Heavy Earth Moving Equipment Simulators**
- **Small Scale Hi fidelity Train Driver Simulators**
- **Next Generation Unsupervised Coin-operated Motion Simulator Arcade Machines**
- **Home Built Hi fidelity Flight Simulators**
- **Home Built Hi fidelity Car Racing Simulators.**

---

## General Description and Capabilities

The CKAS W3s 6DOF Motion System is Ideal for OEM manufacturers of existing simulator products or home builders who are looking for a cost effective method to instantly add high fidelity full 6DOF motion to an existing or new design. This unit is pre-built to CKAS standards, and is USB plug and play straight out of the box. The only assembly required is to bolt on whatever goes on top of the motion system.

The CKAS W3s 6DOF Motion System features a mere 200kg total weight, 1160mm total width, and sits only 360mm high when parked, therefore eliminating the need for any specialised stair or gangway for stepping up onto it. CKAS has used the technology it has developed for the heavier motion systems to design this unit, incorporating industry leading electronics, encoders and actuators.

The expected life of the W3s is extremely high for its price point, and the maintenance requirements are minimal, especially important in commercial or consumer based applications.

The CKAS W3s 6DOF motion system comes with the following key features:

- Fully Electric Actuation
- USB 2.0 plug and play
- Ethernet 100BaseT interface for custom OS/Platform independent applications (optional extra)
- On board Washout filters and acceleration onset cueing algorithms for:
  - Microsoft Flight Simulator FSX / Microsoft ESP / Lockheed Martin Prepar3D
  - X-Plane 9 / 10
  - rFactor (v1.255 or higher) and rFactor2
  - iRacing
  - Generic custom user program or other systems with full washout cueing, inverse kinematics, forward kinematics and full diagnostics on board the motion system
- Configurable to be connected directly to X-Sim to support over 40 other popular games such as Dirt/Dirt2/Dirt3 F1 2010/2011/2012/2013/2014 and many more
- Basic Serial over USB or optionally UDP (over Ethernet or Local) interface for immediate connection to custom software
- Very high speed update 100Hz motion controller for extremely smooth high fidelity response

## Specific “On-board” Functionalities

This motion system features the CKAS Generation III controller which has some very high level functionality available to the user, without the need for any CKAS software to be running on a host PC. The client software can directly interface to the motion system at a very high level, and is even platform independent with the optional Ethernet Module installed.

The CKAS Generation III controller features the following specific capabilities on board:

- **Full Inverse Kinematics** allowing the user to drive the machine in Cartesian co-ordinates from any custom application, over either USB serial (Windows/Linux only) or completely platform independent through an optional Ethernet Interface.
- **Full Forward Kinematics** allowing the user to read the actual current position of the motion system in real-time, allowing for a wide range of applications, including when the visual system is not mounted on the motion system and needs to be synchronised in the graphics (client software required to perform the graphical synchronisation).
- **Washout Cueing Filters** allowing the client to send high level kinematics data to the motion system in order to recreate the vehicle motion through the washout filters, all completely independent of any other software, and even completely platform independent on the optional Ethernet Interface.

## General Specifications

(Subject to change without notification)

Product Name	CKAS W3s 6DOF Motion System
Product Code	W3sMP
Product Number	38.0001.11
Product Description	Small Scale 6 degree of freedom electric motion system
Harmonization Code (HS)	854370 or 854380 or 8543.70.96.50 (depending on Harmonisation system)

## Mechanical Specifications

Architecture	6 Degree of Freedom Modified Stewart Hybrid
Actuation	Fully Electric
Nominal Width (Parked)	1160 mm (45.7")
Nominal Length (Parked)	1160 mm (45.7")
Nominal Height (Parked)	360 mm (14.2")
Approx unit weight	200 kg (440 lb)
Anchoring Specification	Not required for this motion system – Rubber mat recommended

## Performance Specifications

Payload Mass Limit	300 kg (660 lb)
Payload Moment of Inertia	100 kg.m <sup>2</sup> (2,610 lb.ft <sup>2</sup> )
Payload CG horizontal offset	Less than 50mm from Centroid of Flying Platform
Payload CG Vertical offset	Less than 600mm high from top of Flying Platform
Payload Max Floor Size	Diameter 2000mm (79")
Indep. Surge (disp. / vel. / accel.)	±50mm , ±100mm/s , 0.3G
Indep. Sway (disp. / vel. / accel.)	±50mm , ±100mm/s , 0.3G
Indep. Heave (disp. / vel. / accel.)	±50mm , ±100mm/s , 0.3G
Indep. Yaw (disp. / vel. / accel.)	±10° , ±15°/s , ±150°/s <sup>2</sup>
Indep. Pitch (disp. / vel. / accel.)	±10° , ±15°/s , ±150°/s <sup>2</sup>
Indep. Roll (disp. / vel. / accel.)	±10° , ±15°/s , ±150°/s <sup>2</sup>
Max Motion Excitation Frequency	50 Hz

## Electrical Specifications

Power Supply Requirements	200 – 250V AC Single Phase @ 6 Amps
PC Connectivity	USB 2.0
Controller Update Frequency	100 Hz

## Software Specifications

Interface Protocols	Serial over USB (Windows/Linux) / Optional Ethernet (OS independent)
Washout Algorithm Drive	Washout System with 6DOF optimisations for: <ul style="list-style-type: none"><li>• Microsoft FSX / ESP / Lockheed Martin Prepar3D (Windows only)</li><li>• X-Plane 9 / 10 (Windows only)</li><li>• rFactor (v1.255 or higher) and rFactor2 (Windows only)</li><li>• iRacing (Windows only)</li><li>• Generic User Applications (any platform with Ethernet)</li></ul>
Direct Drive	Extended command set over Serial or (optional) Ethernet

**View of Base Mounting Holes from TOP**

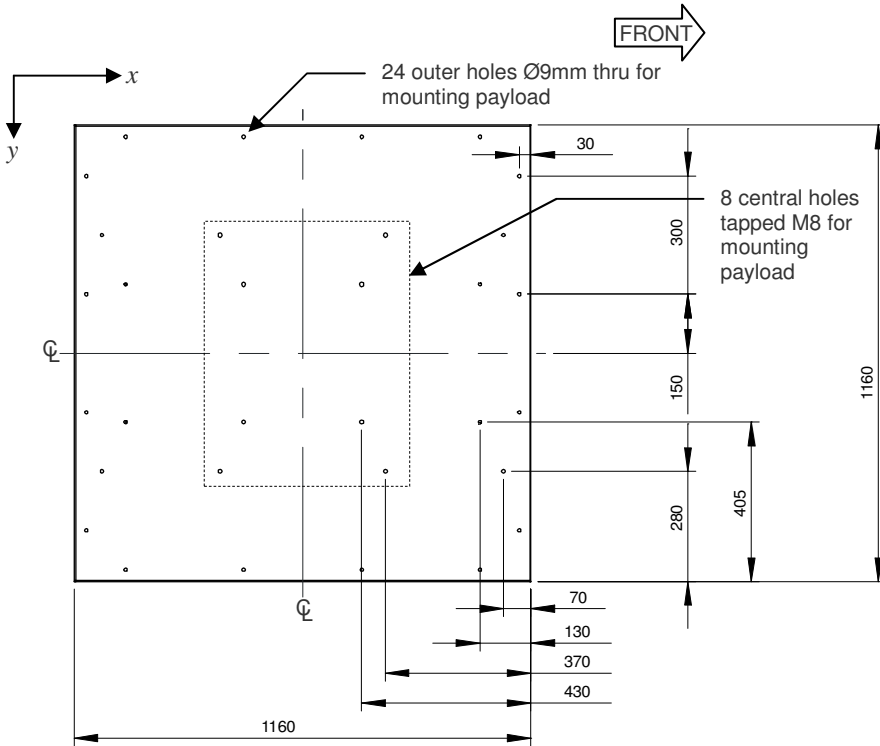

**View of Motion System from RIGHT**

**View of Motion System from FRONT**

